



Phoneme Matching

PA. 032

Final Sound Match-Up

Objective

The student will match final phonemes in words.

Materials

- ▶ Final sound picture boards
- ▶ Final sound picture cards

Activity

Students count the syllables in words and place cards in corresponding boxes.

1. Place final sound picture cards face down in a stack on a flat surface. Provide each student with a different picture board.
2. Taking turns, students select the top card, name it, and say its final sound (e.g., “swim, /m/”).
3. Find the picture on the board with the same final sound and name it (i.e., “vacuum, /m/”). Place the card on that picture.
4. Continue until all pictures are matched.
5. Peer evaluation

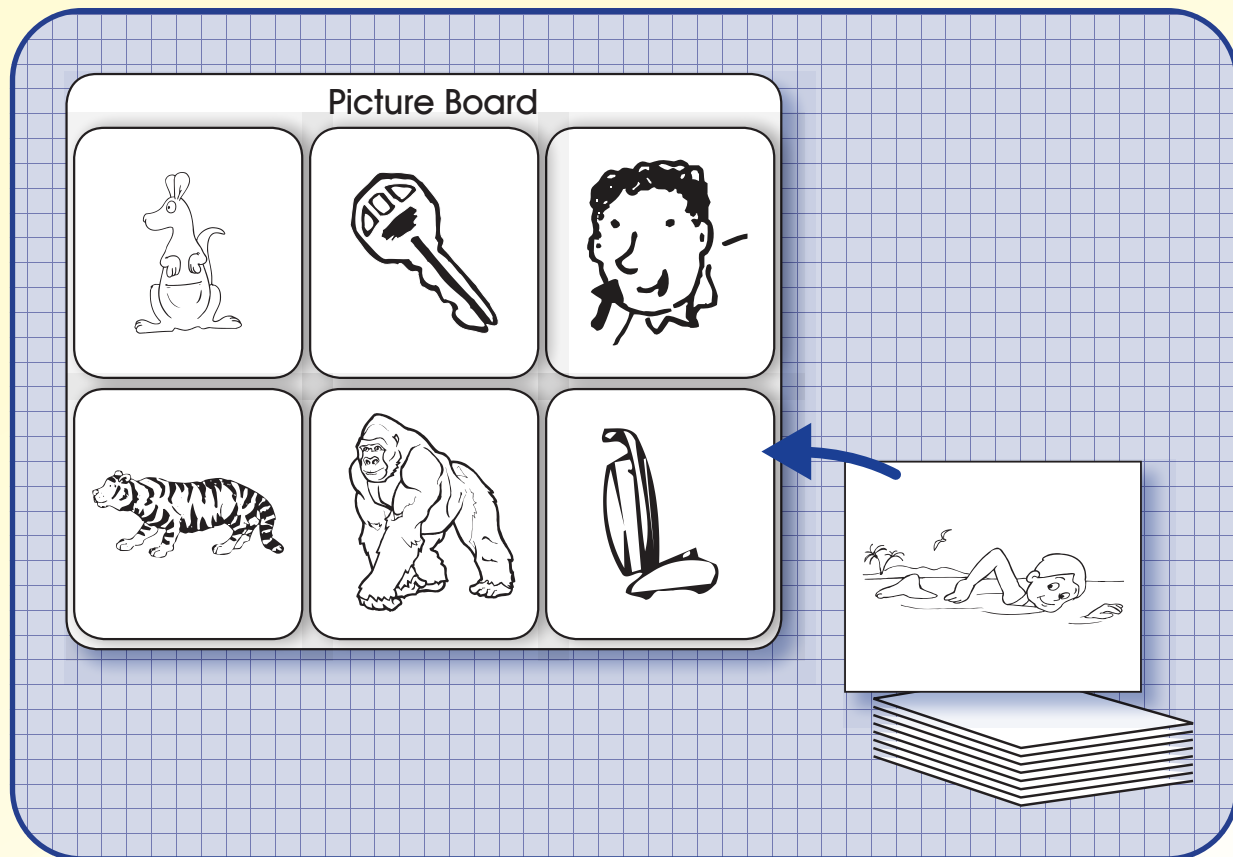

Extensions and Adaptations

- ▶ Exchange picture boards and repeat activity.
- ▶ Make and use other target picture boards.
- ▶ Use objects with corresponding final sounds to match to pictures on boards.

Phonological Awareness

PA. 032

Final Sound Match-Up

Picture Board

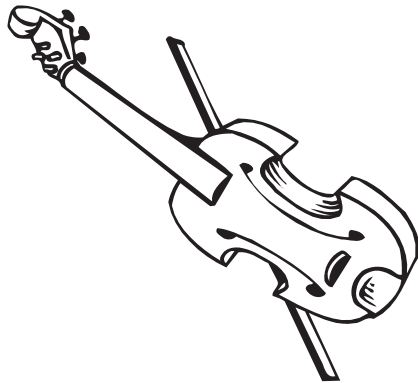
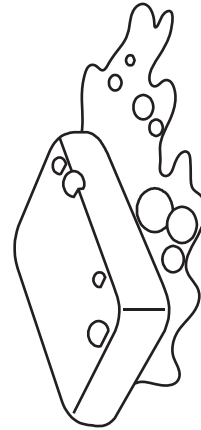
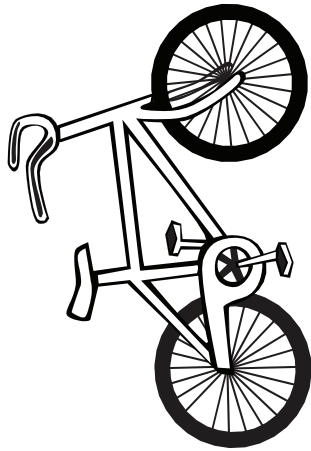

8

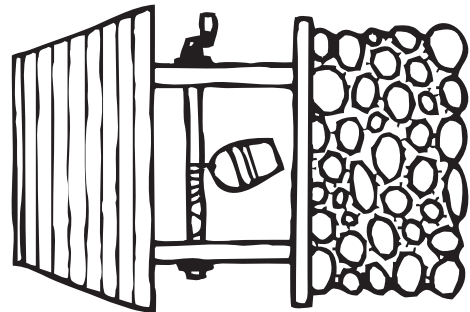

final sound picture board: eight, violin, bike, well, pie, soap



Phonological Awareness

Final Sound Match-Up

PA. 032

Picture Board

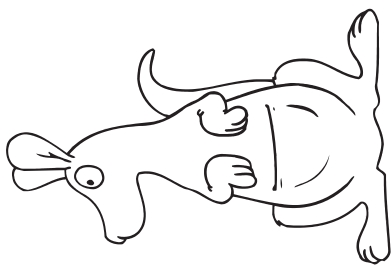
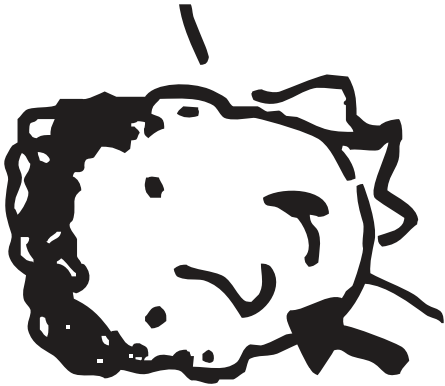

final sound picture board: kangaroo, key, nose, tiger, gorilla, vacuum



Phonological Awareness

PA. 032

Final Sound Match-Up

Picture Board

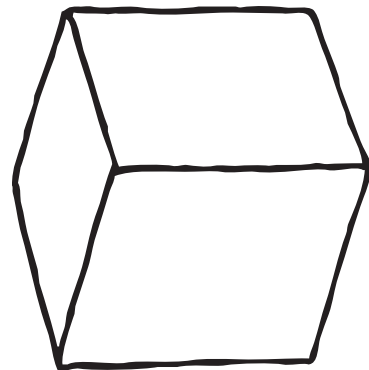
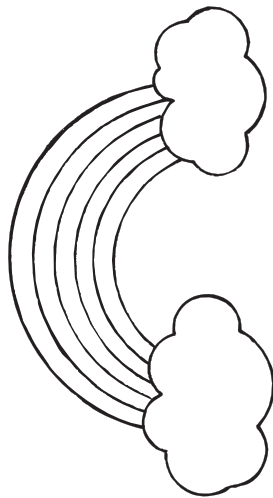
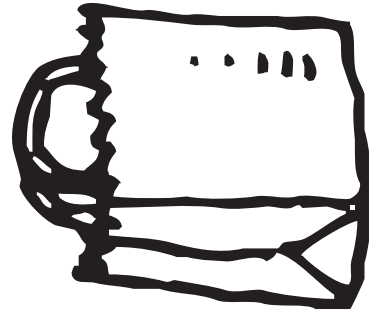
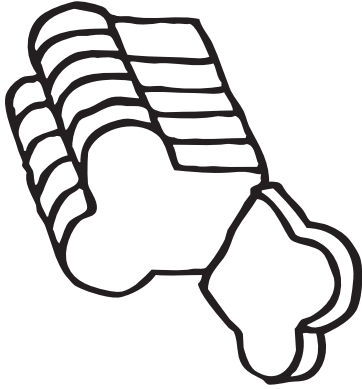

final sound picture board: ostrich, rainbow, bread, cube, ring, bag



Phonological Awareness

Final Sound Match-Up

PA. 032

Picture Board

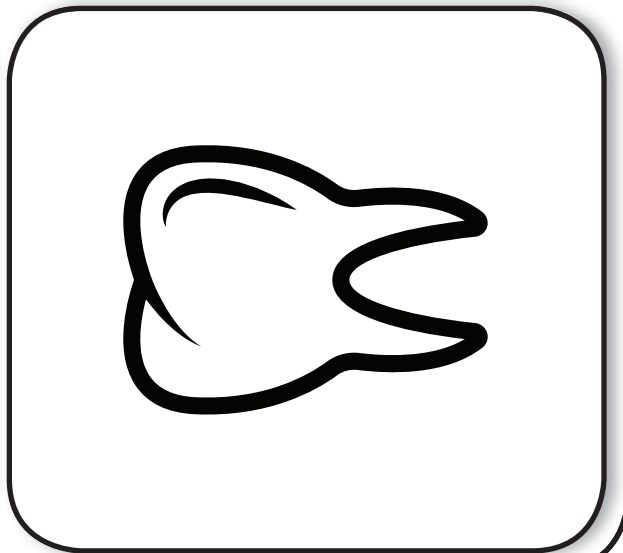
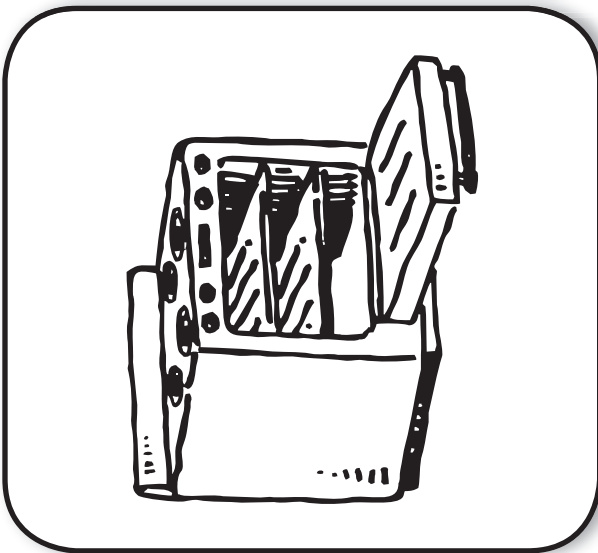
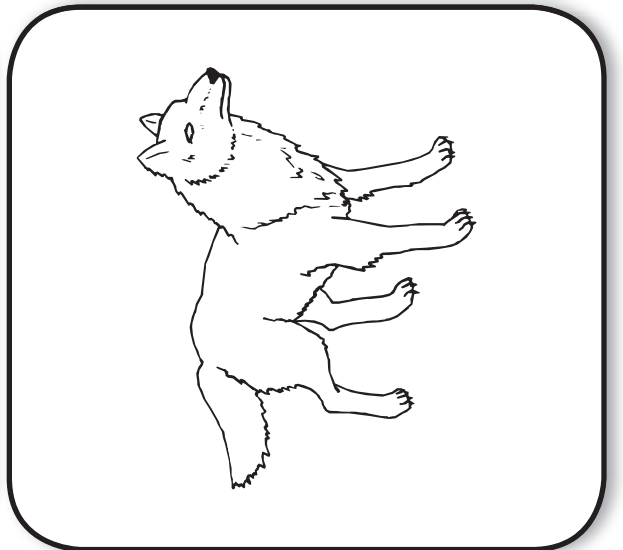
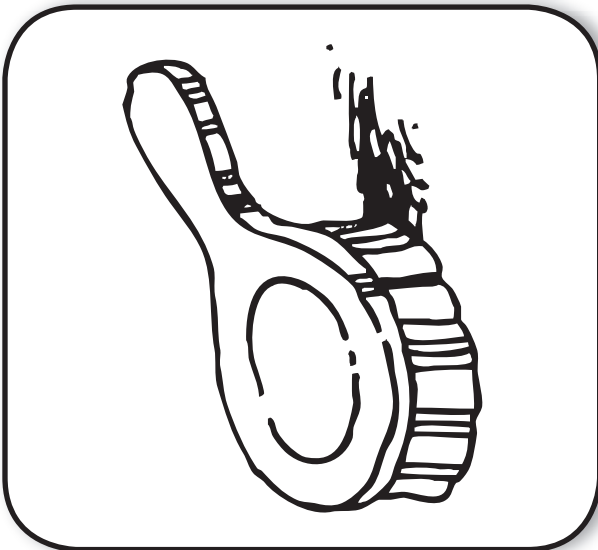
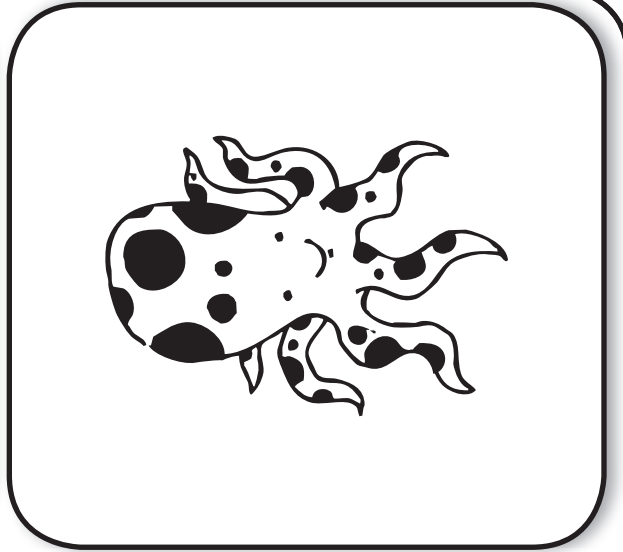
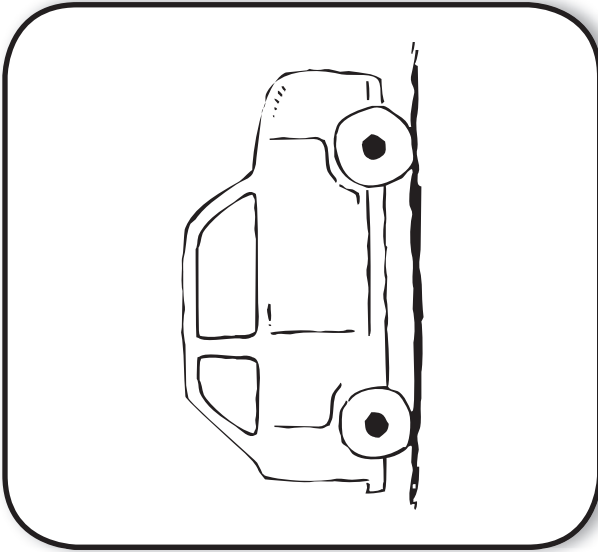







final sound picture board: stove, brush, car, tooth, wolf, octopus

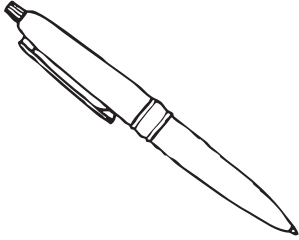
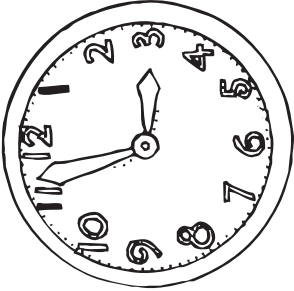

Phonological Awareness

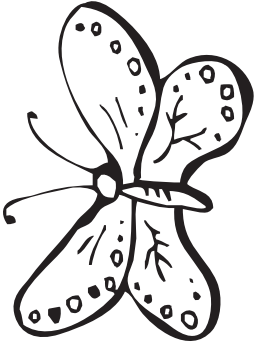
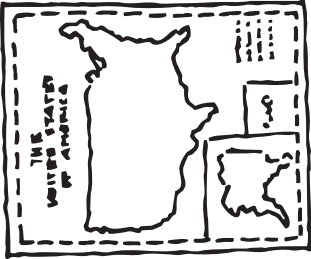
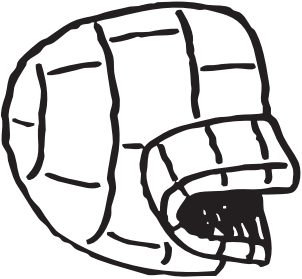
PA. 032

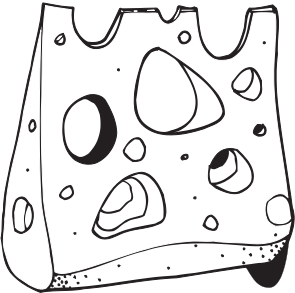
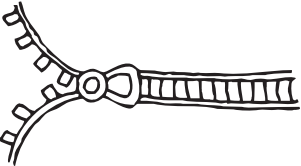
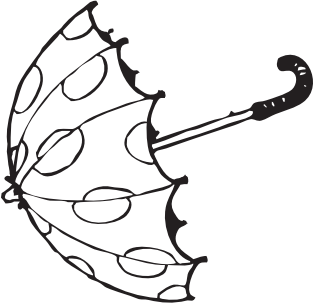
Final Sound Match-Up

final sound picture cards:











peanut, pen, clock, nickel, butterfly, map, igloo, baby, cheese, zipper, umbrella, swim

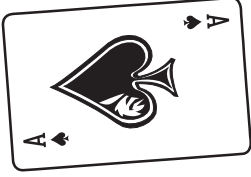

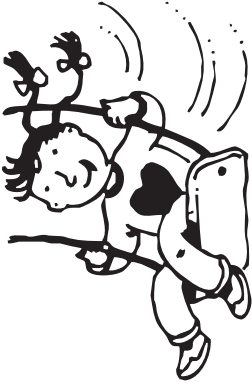
Phonological Awareness

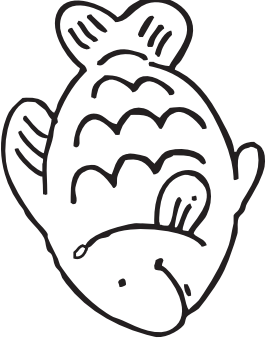
Final Sound Match-Up

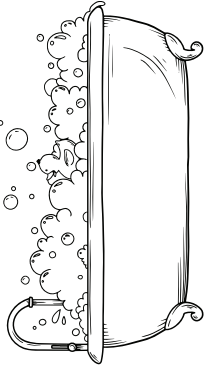
PA. 032

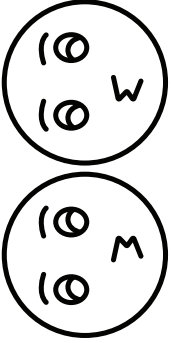
final sound picture cards:

watch, cub, card, radio, swing, log, cave, fish, star, bath, elf, kiss



Phonological Awareness

PA. 032

Final Sound Match-Up

Picture Board

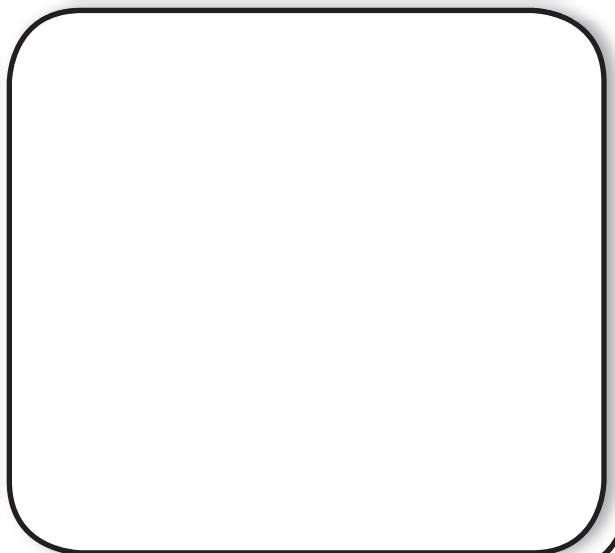
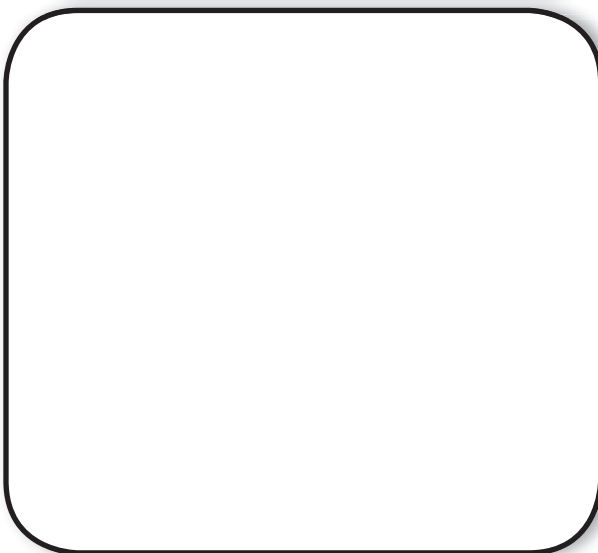
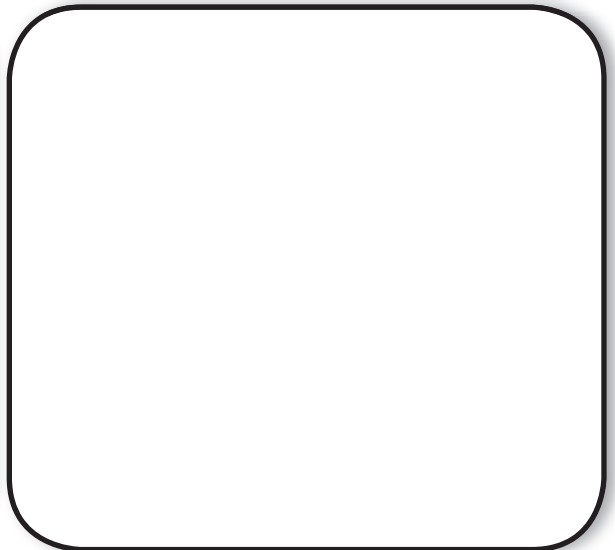
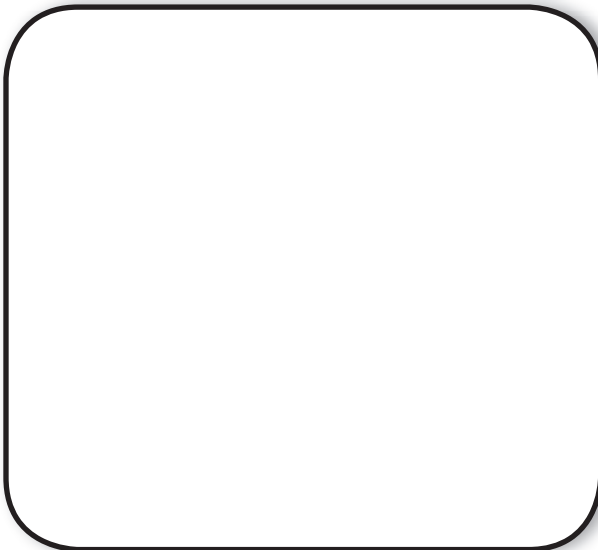
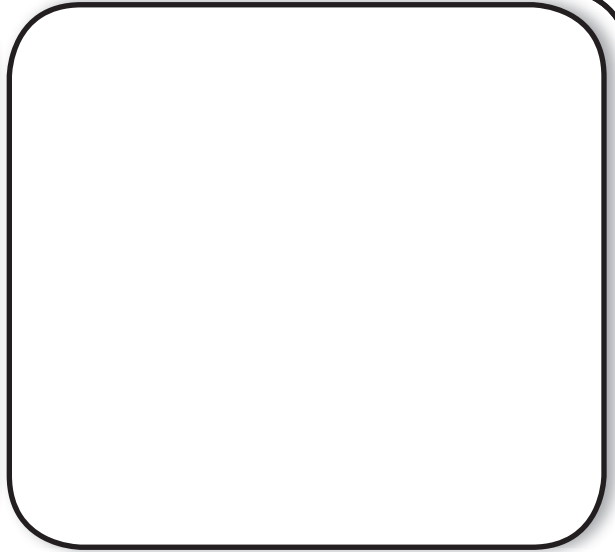
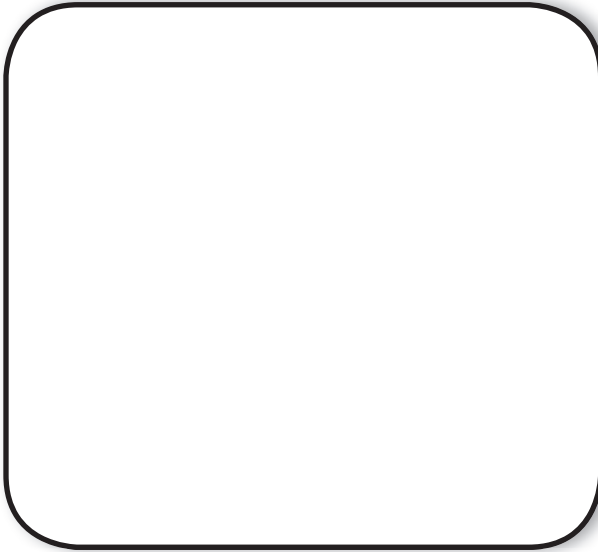

blank picture board

