

# Phonological Awareness



## Phoneme Matching

PA. 029

### Phoneme Go Fish



#### Objective

The student will match initial phonemes in words.



#### Materials

- ▶ Initial sound picture cards



#### Activity

Students group initial sound pictures while playing a Go Fish game.

1. Mix picture cards into three separate and equal stacks. Each student gets one stack and the remaining stack is the “pond.”
2. Working in pairs, students name their cards, pair by initial sound, and put aside the matching sets.
3. Student one looks at his remaining cards and asks for a picture card that begins with a certain letter-sound (e.g., “Do you have a picture that begins with /r/?”).
4. If yes, student one takes the card, names the card, and says the initial sound of both pictures, places match aside, and takes another turn. If no, student two says, “Go fishing for a match!”
5. Student one then selects a card from the “pond.”
6. Continue until all cards are matched.
7. Peer evaluation

"Do you have a picture that begins with /r/?"

"No. Go fishing for a match!"

A stack of blank cards is shown in the center, representing the 'pond'.



#### Extensions and Adaptations

- ▶ Play with other initial sound picture cards.

# Phonological Awareness

PA. 029

Phoneme Go Fish

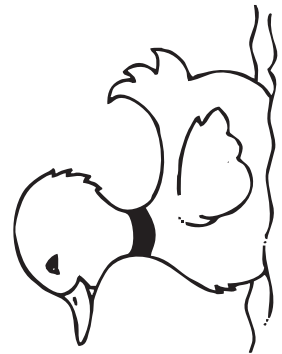
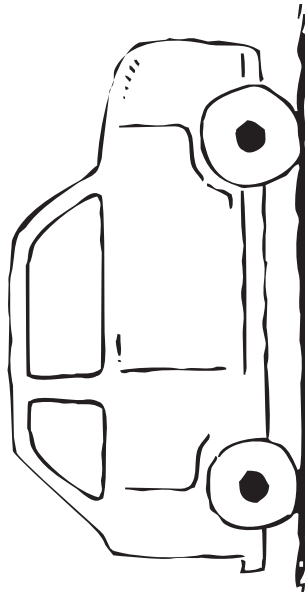
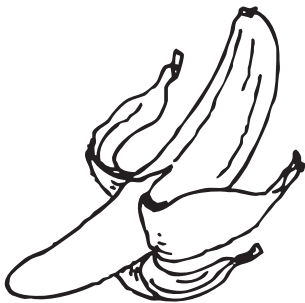
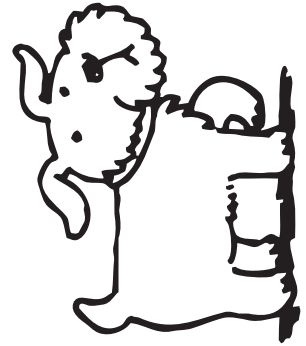
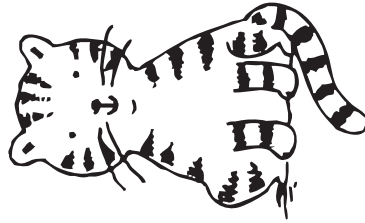

initial sound picture cards: bear, cat, dog, banana, car, duck



# Phonological Awareness

Phoneme Go Fish

PA. 029

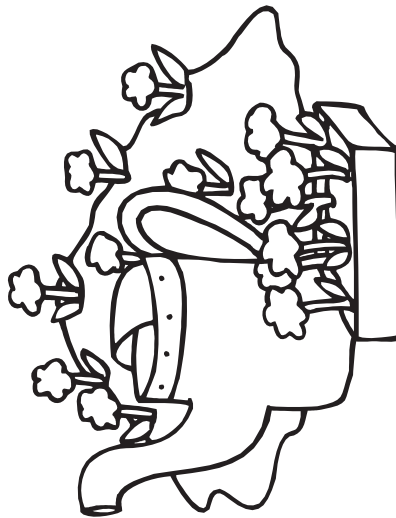
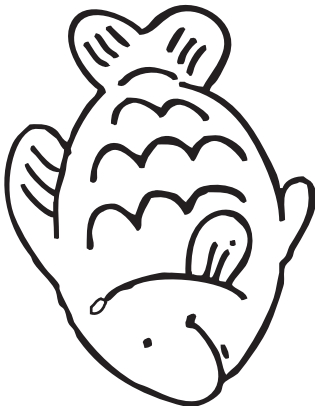
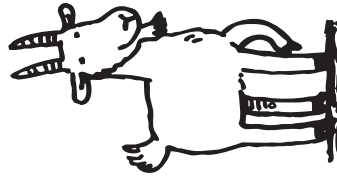
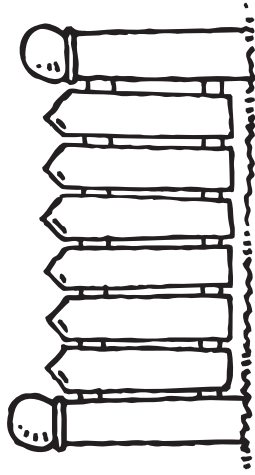

initial sound picture cards: fence, goat, hat, fish, garden, horse



# Phonological Awareness

PA. 029

Phoneme Go Fish

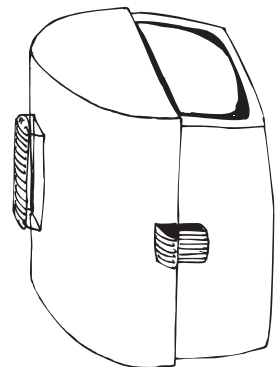
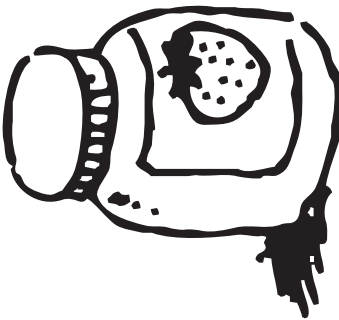
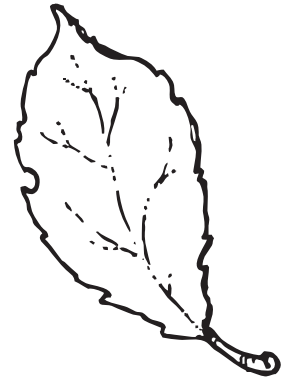
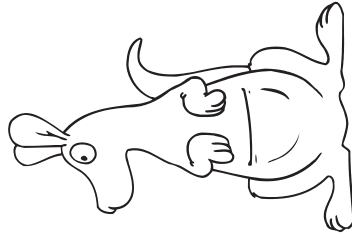
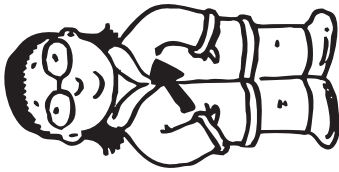

initial sound picture cards: jacket, kangaroo, leaf, jam, king, lunchbox



# Phonological Awareness

Phoneme Go Fish

PA. 029

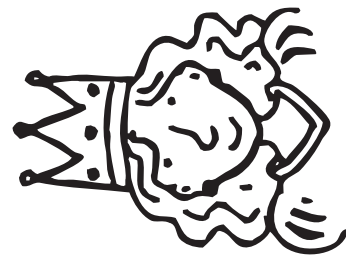
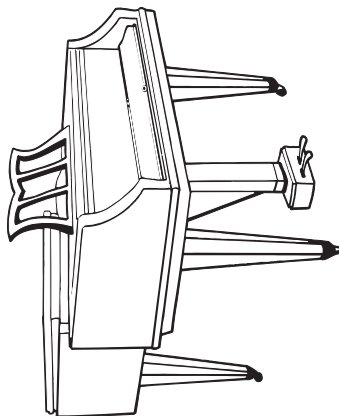
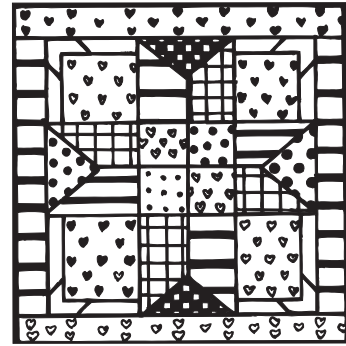
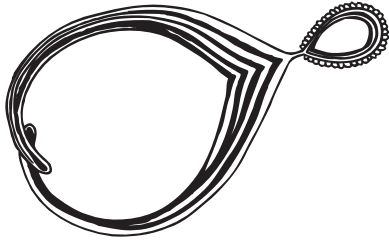

initial sound picture cards: necklace, penny, quilt, nickel, piano, queen



# Phonological Awareness

PA. 029

Phoneme Go Fish

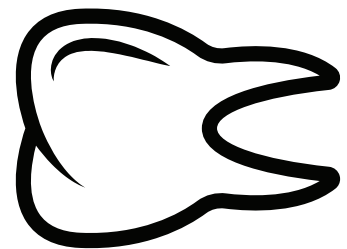
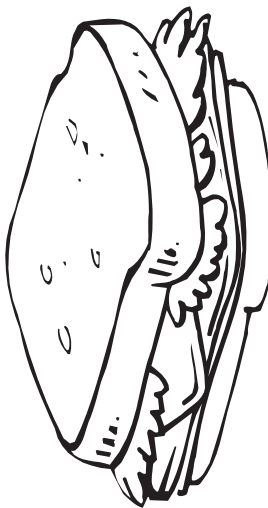
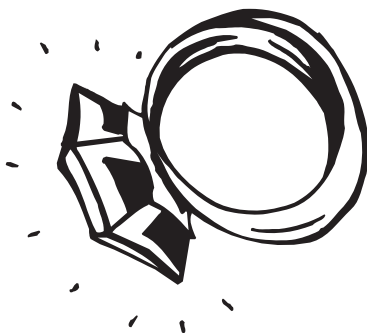
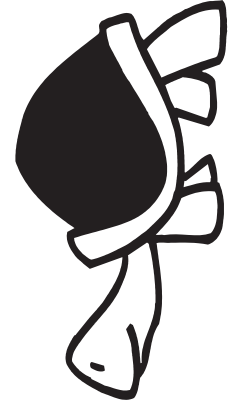

initial sound picture cards: raccoon, seahorse, turtle, ring, sandwich, tooth



# Phonological Awareness

Phoneme Go Fish

PA. 029

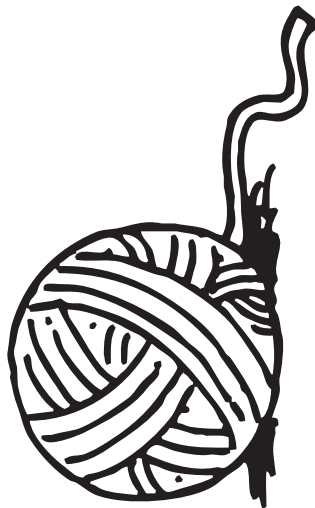
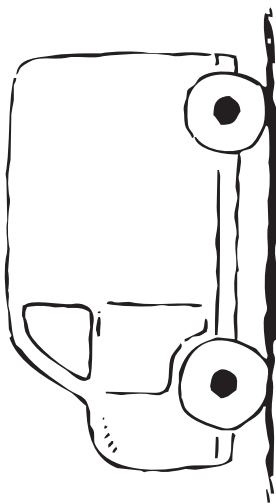
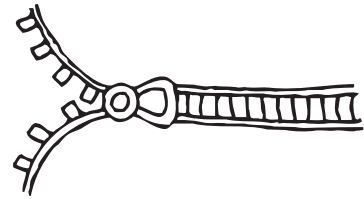
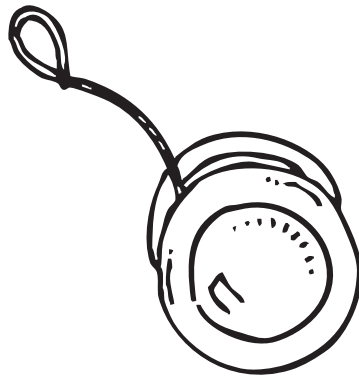
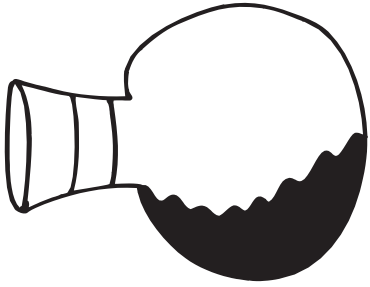

initial sound picture cards: vase, yo-yo, zipper, van, yarn, zebra



# Phonological Awareness

PA. 029

Phoneme Go Fish

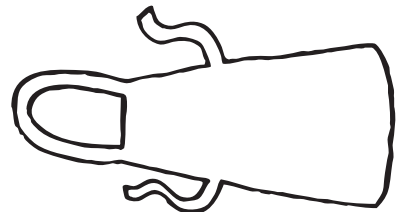
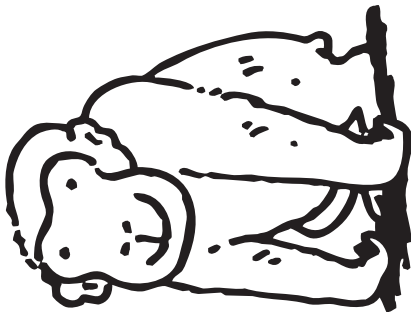
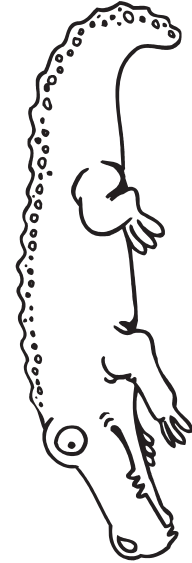
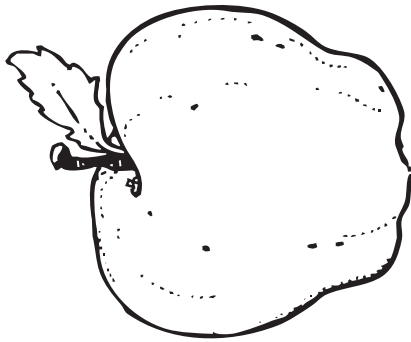
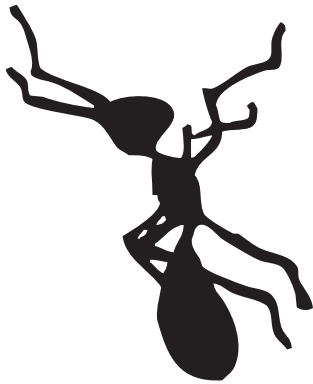

ant, apple, alligator, ax, ape, apron





# Phonological Awareness

Phoneme Go Fish

PA. 029

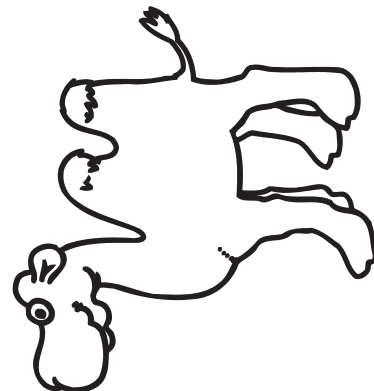
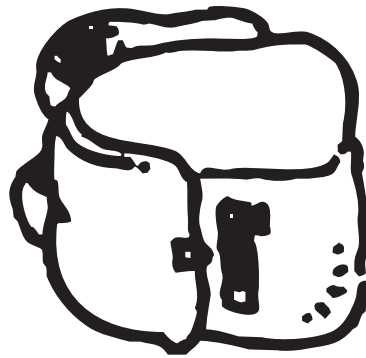
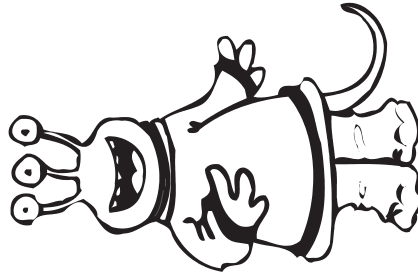
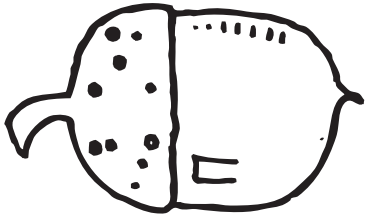

acorn, alien, beach, banana, backpack, camel



# Phonological Awareness

PA. 029

Phoneme Go Fish

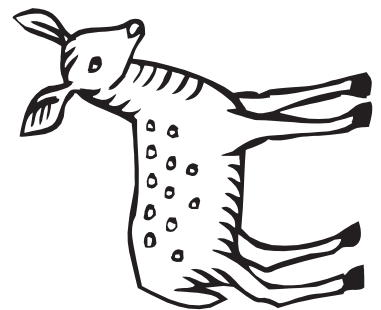
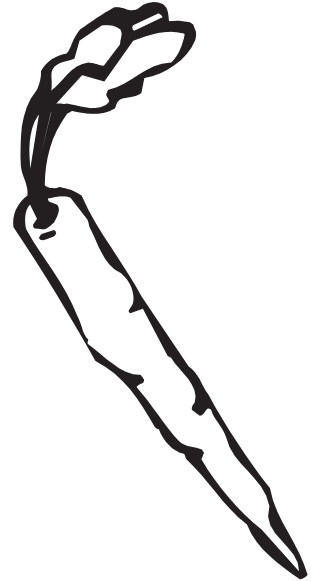
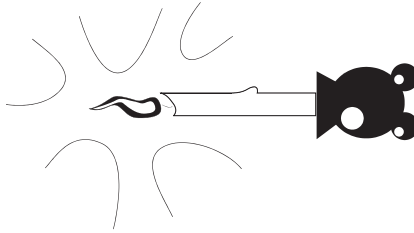

cane, candle, carrot, doughnut, dragon, deer



# Phonological Awareness

Phoneme Go Fish

PA. 029

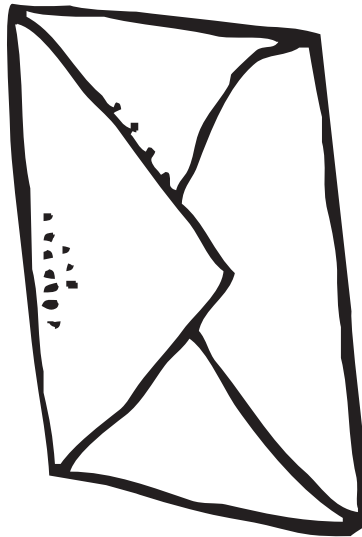
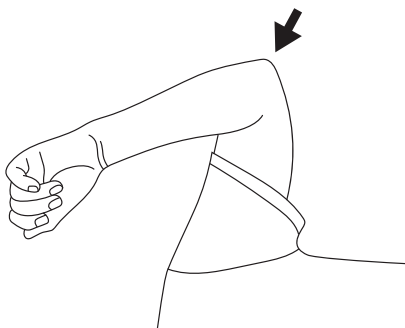
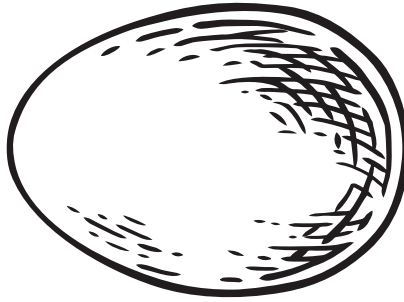
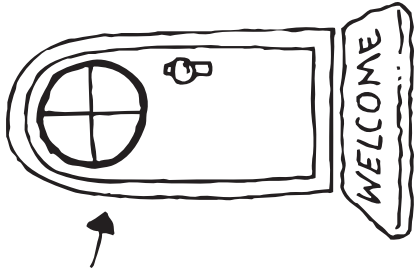

$$2 + 2 = 4$$

An arrow points to the equals sign in the equation.

door, egg, elf, elbow, envelope, equal

# Phonological Awareness

PA. 029

Phoneme Go Fish

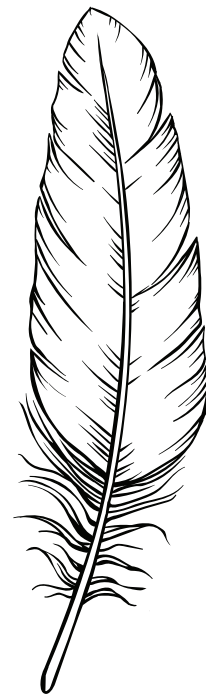
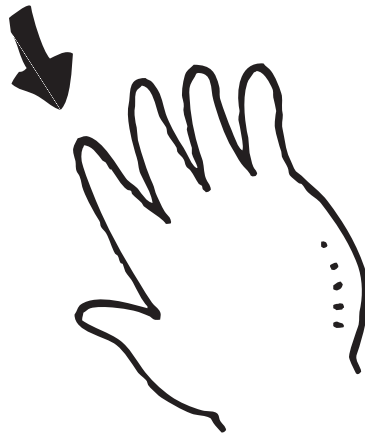
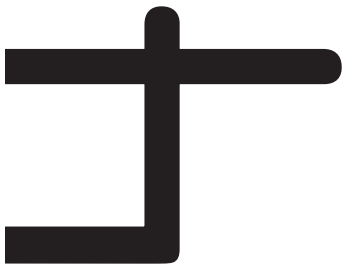
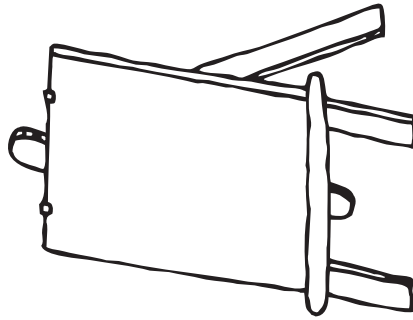

ə, easel, eat, four, finger, feather



# Phonological Awareness

Phoneme Go Fish

PA. 029

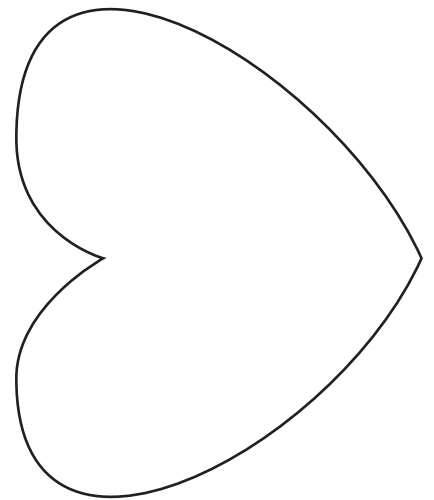
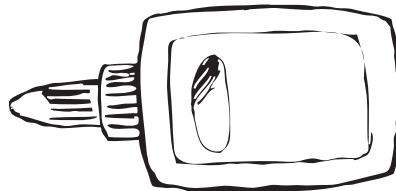
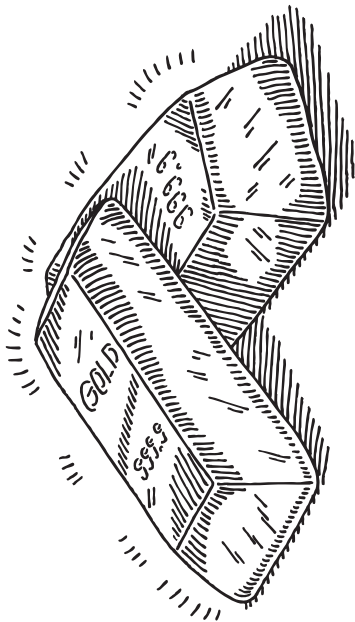
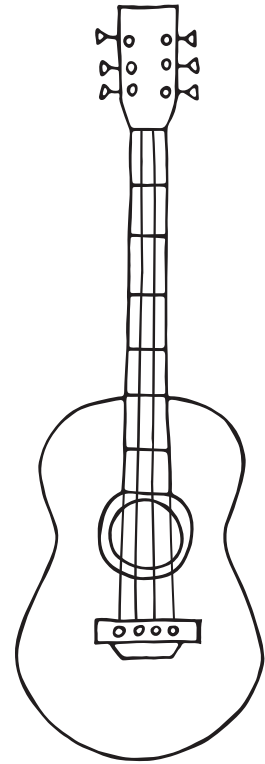
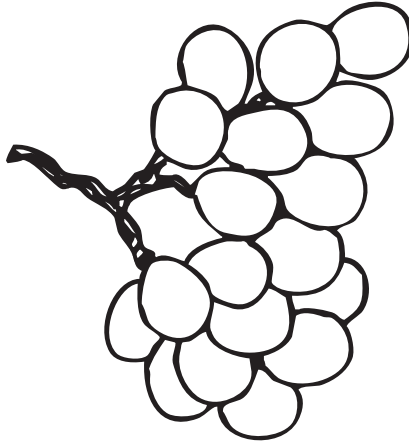
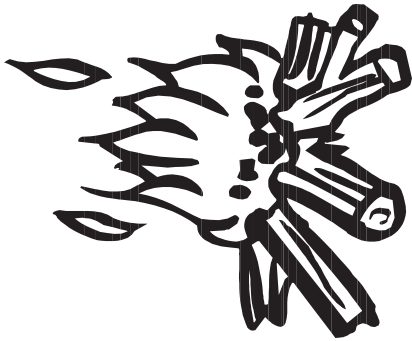

# Phonological Awareness

PA. 029

Phoneme Go Fish

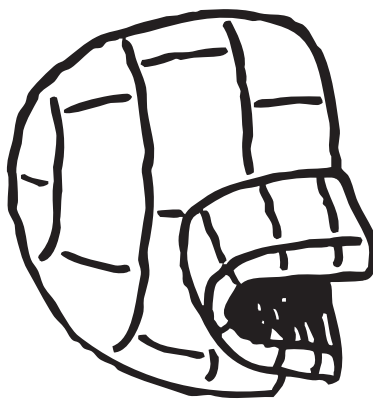
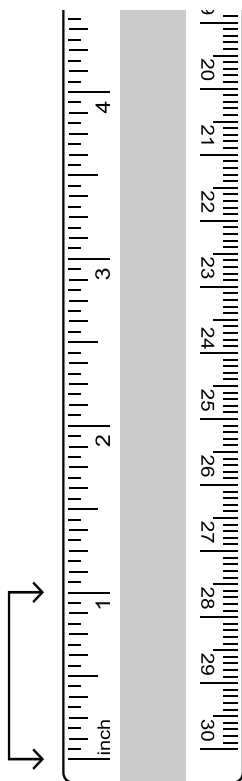
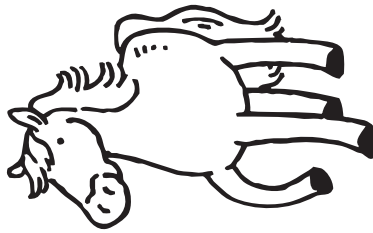

# Phonological Awareness

Phoneme Go Fish

PA. 029

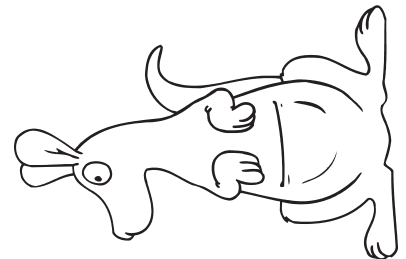
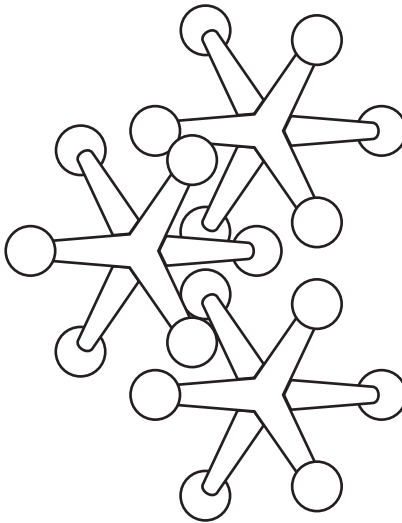
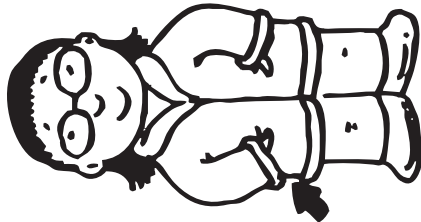
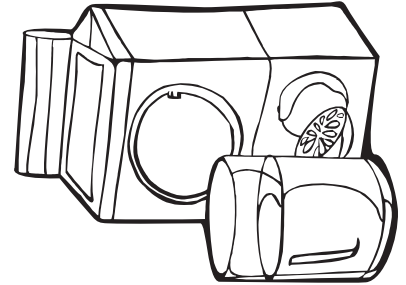
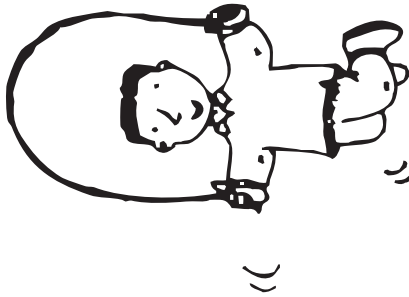
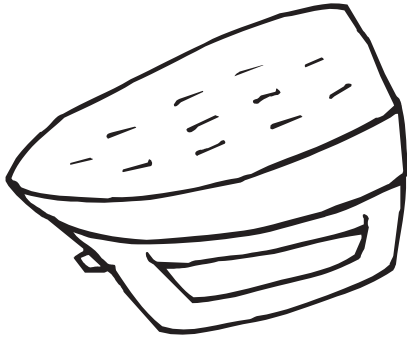

iron, jump, juice, jacket, jacks, kangaroo



# Phonological Awareness

PA. 029

Phoneme Go Fish

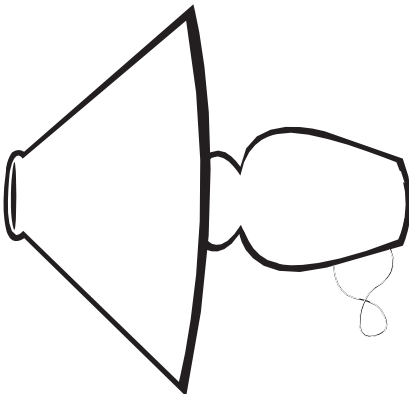
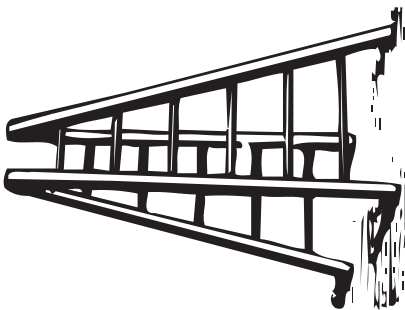
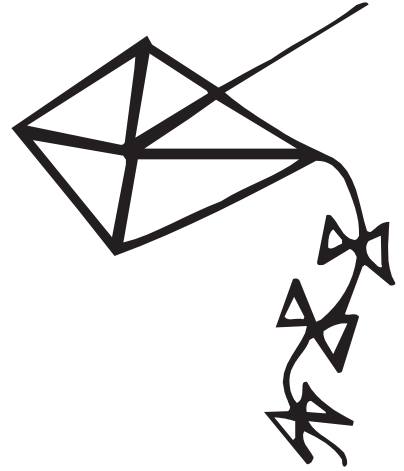
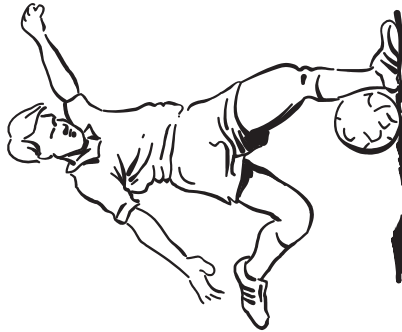

key, kick, kite, ladder, lamp, lion





# Phonological Awareness

Phoneme Go Fish

PA. 029

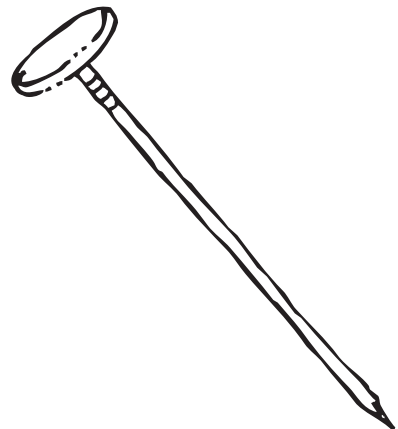
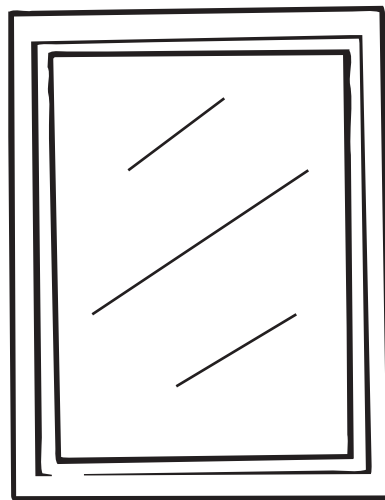
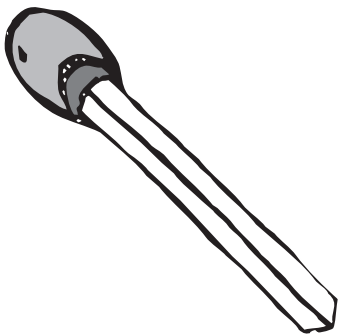
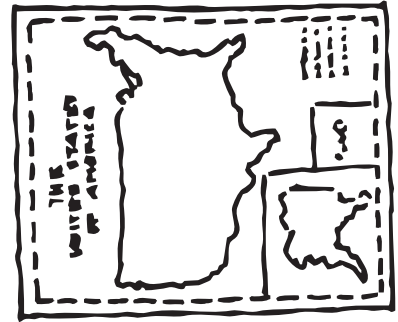
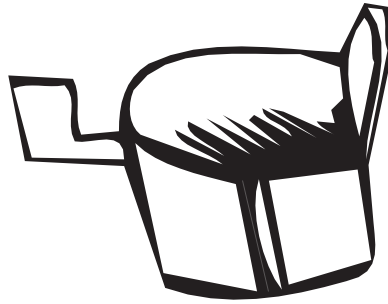
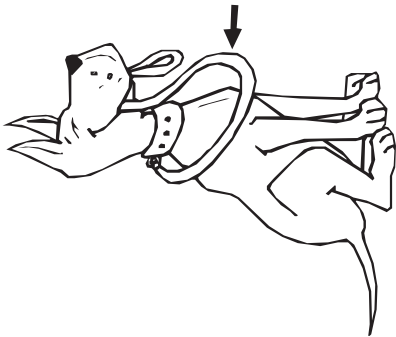

leash, mailbox, map, match, mirror, nail



# Phonological Awareness

PA. 029

Phoneme Go Fish

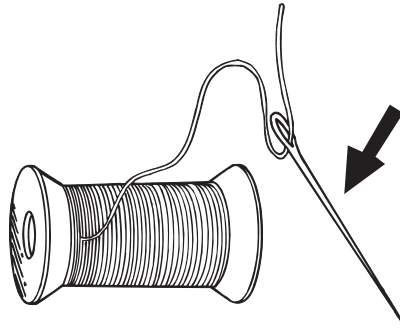
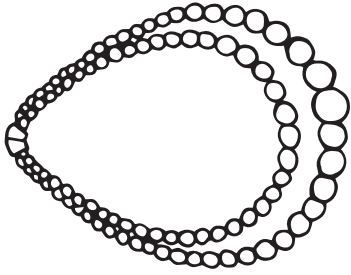

necklace, needle, nurse, octopus, ox, olive



# Phonological Awareness

Phoneme Go Fish

PA. 029

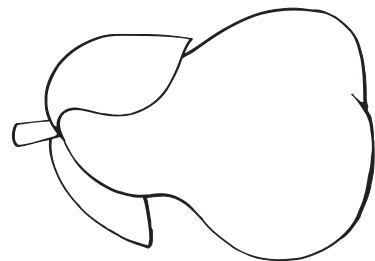
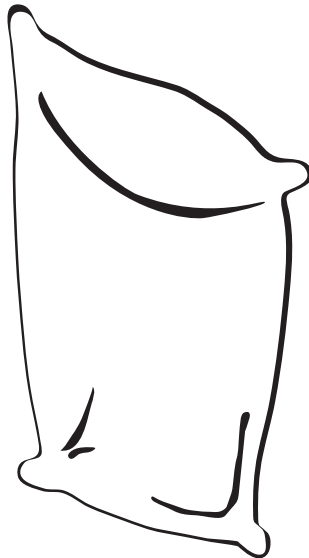
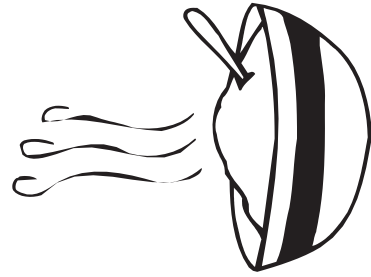
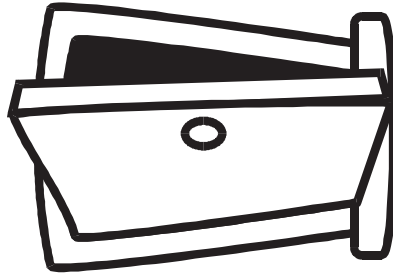

ostrich, open, oatmeal, pretzel, pillow, pear



# Phonological Awareness

PA. 029

Phoneme Go Fish

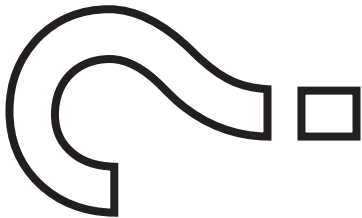
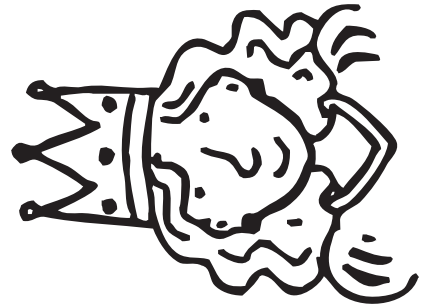
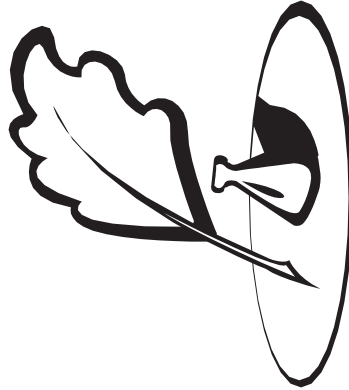
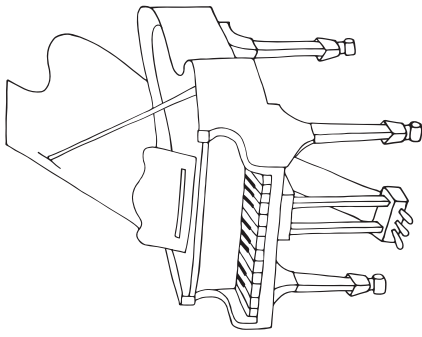

piano, quill, queen, question, quarter, rabbit



# Phonological Awareness

Phoneme Go Fish

PA. 029

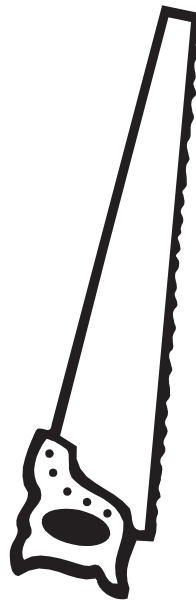
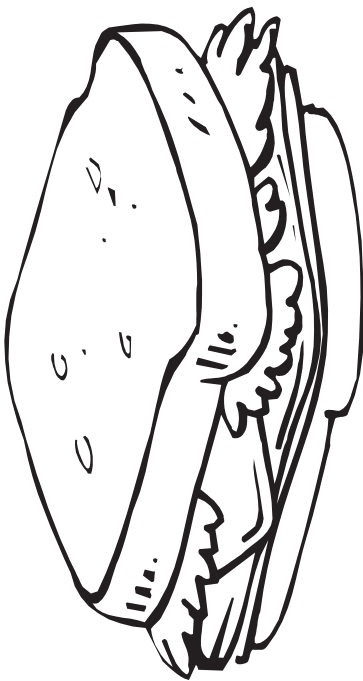
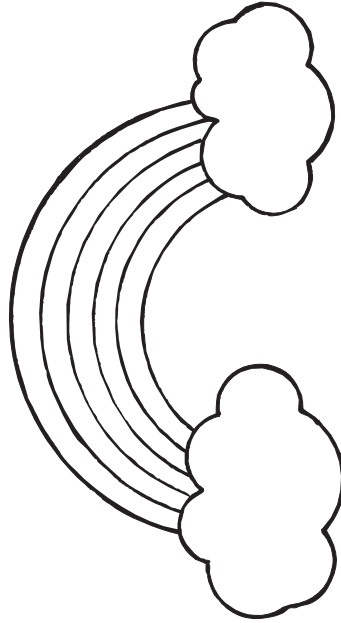
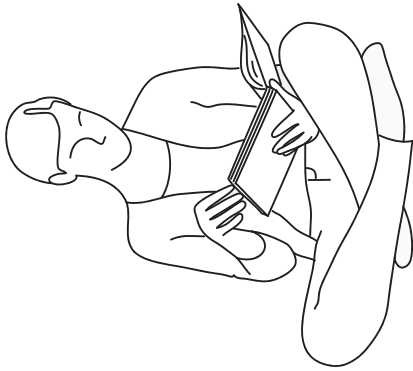

7

read, rainbow, ruler, sandwich, saw, seven

# Phonological Awareness

PA. 029

Phoneme Go Fish

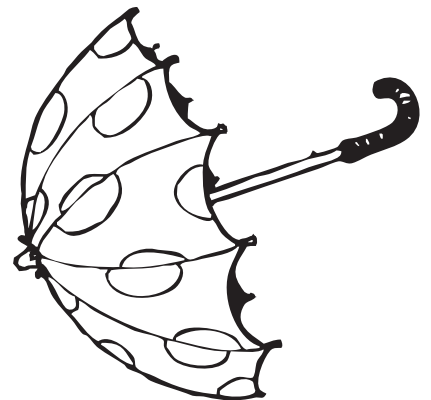
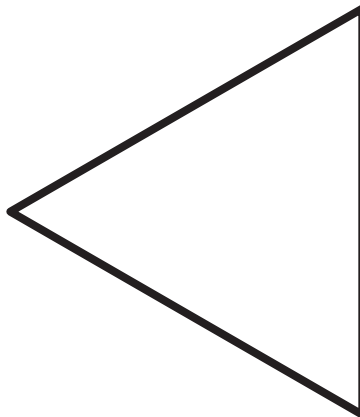
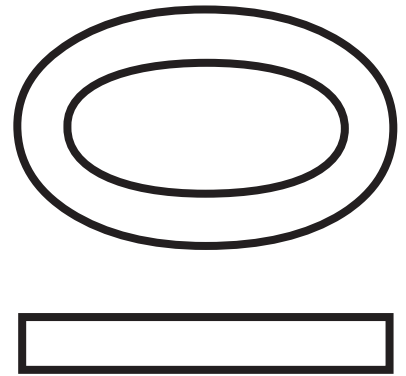
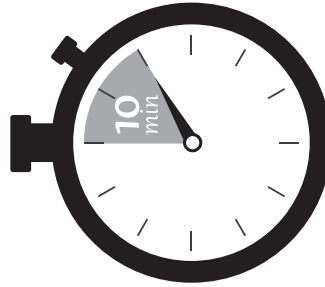

# Phonological Awareness

Phoneme Go Fish

PA. 029

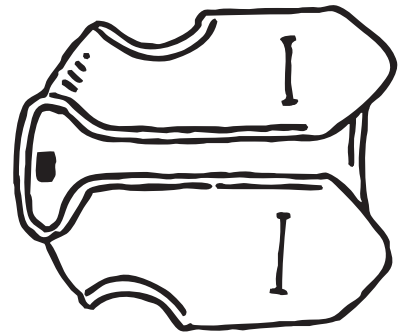
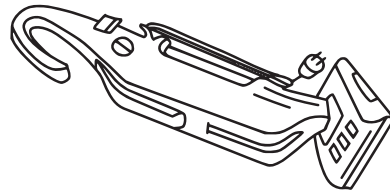
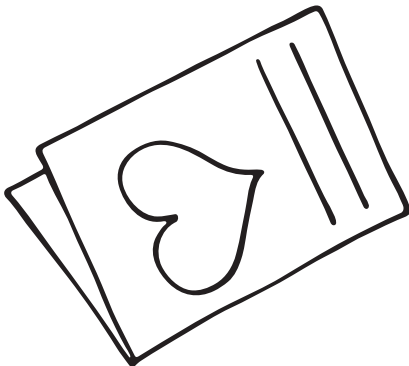
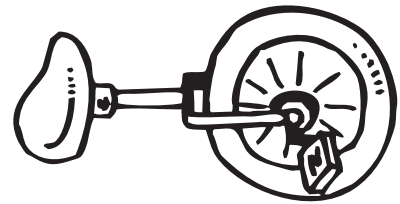
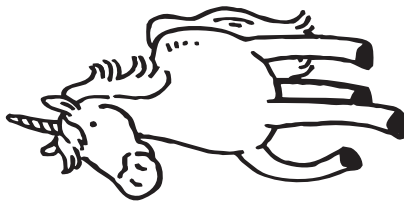

umpire, unicorn, unicycle, valentine, vacuum, vest



# Phonological Awareness

PA. 029

Phoneme Go Fish

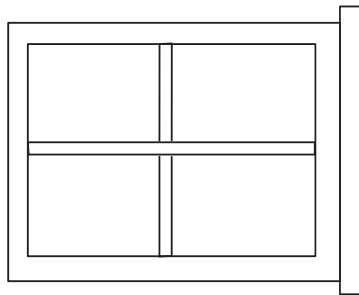
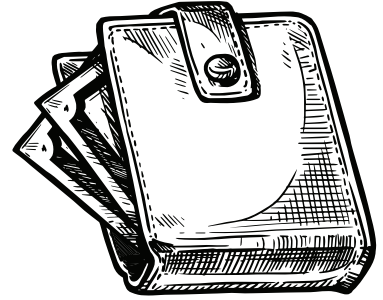
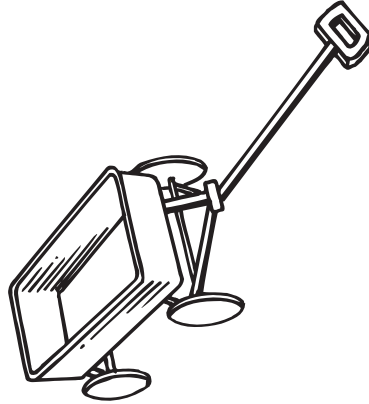
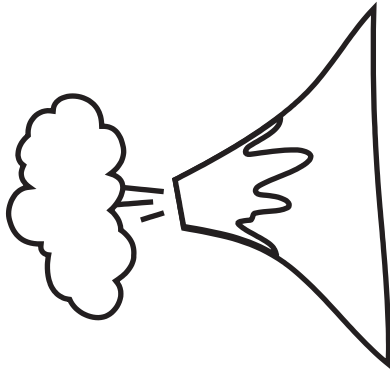

volcano, wagon, wallet, watch, window, yarn





# Phonological Awareness

Phoneme Go Fish

PA. 029

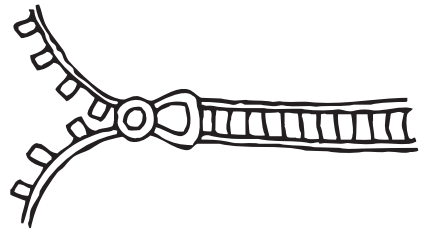
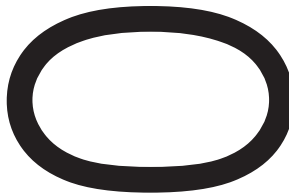

yawn, yo-yo, yak, zebra, zero, zipper



# Phonological Awareness

PA. 029

Phoneme Go Fish

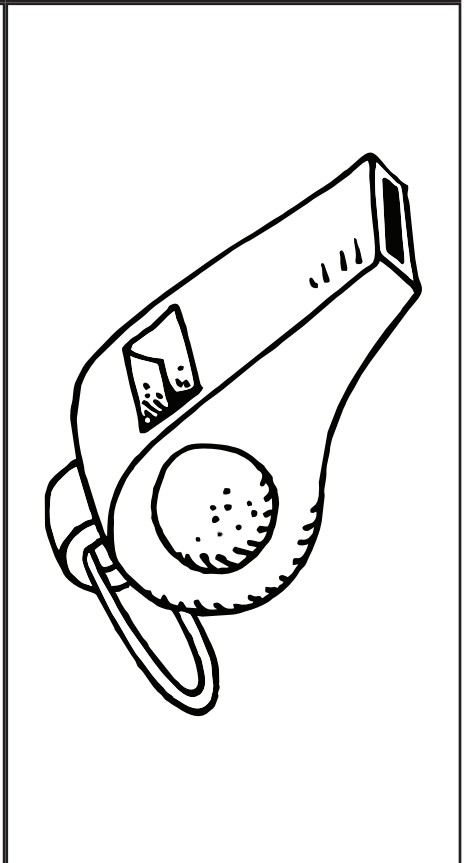
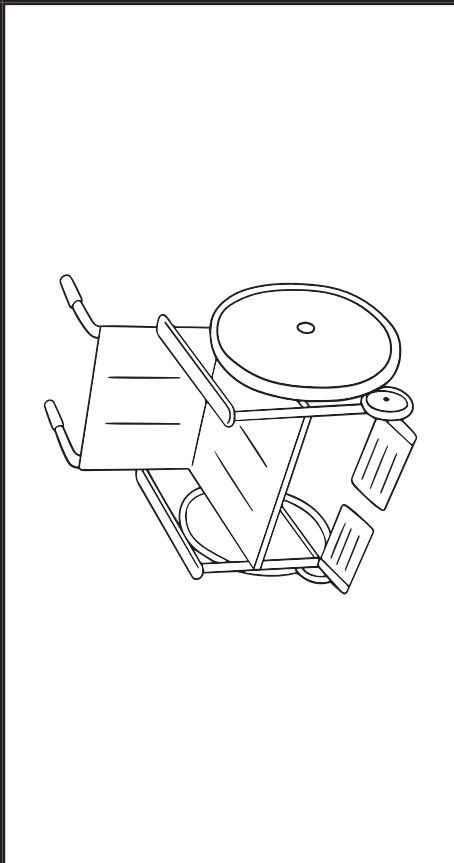
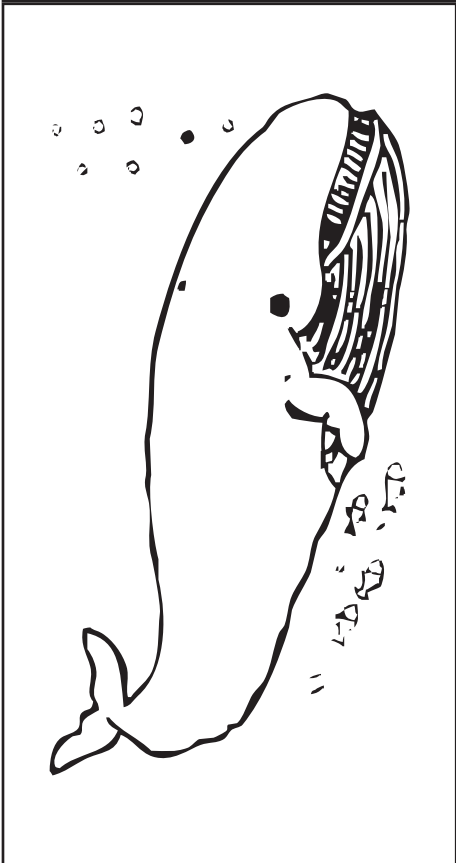
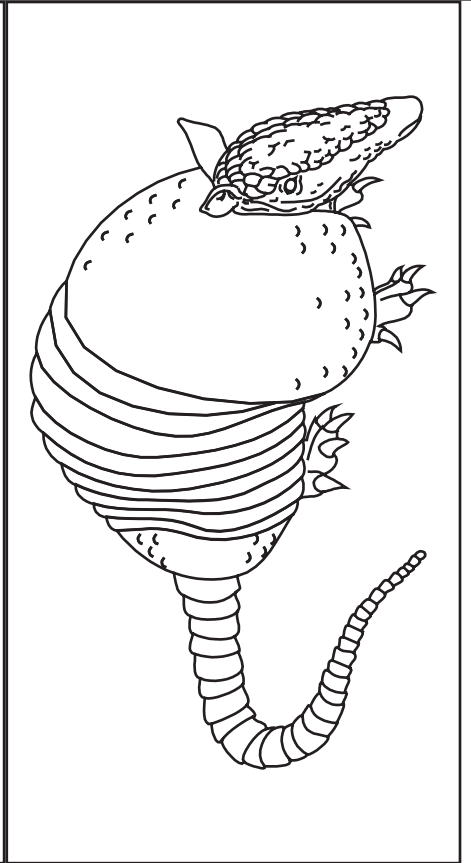
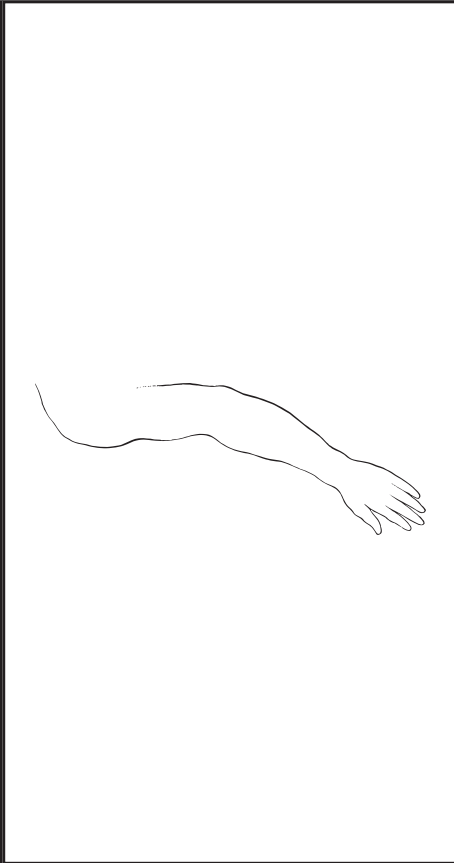
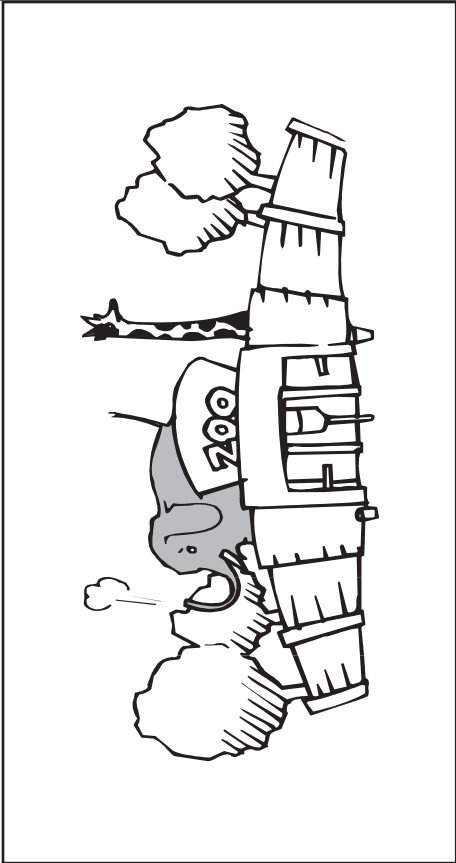

zoo, arm, armadillo, whale, wheelchair, whistle



# Phonological Awareness

Phoneme Go Fish

PA. 029

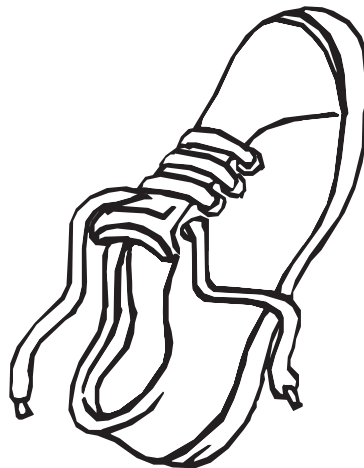
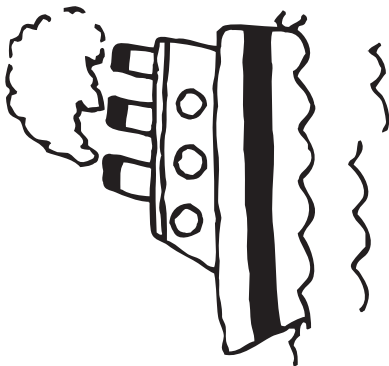
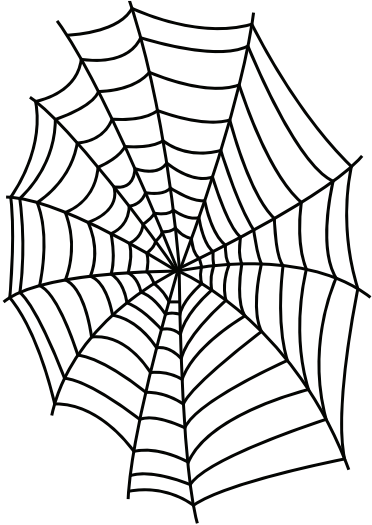

web, shark, shell, ship, shoe, thermometer



# Phonological Awareness

PA. 029

Phoneme Go Fish

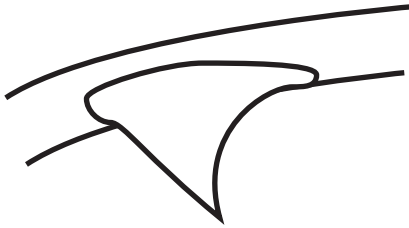
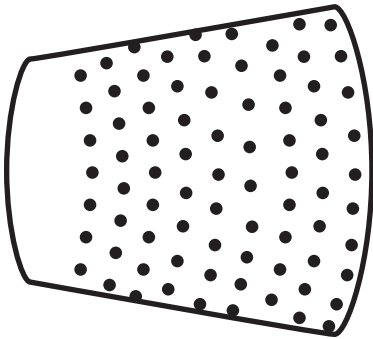

30

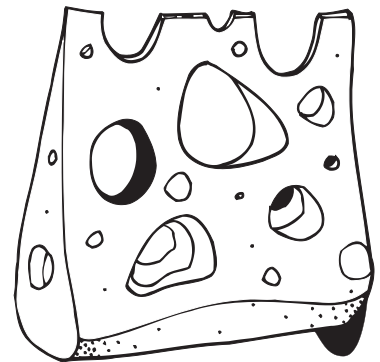
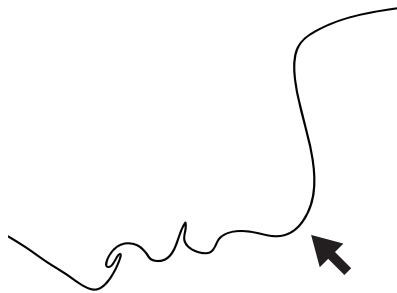

thimble, thorn, thirty, check, chin, cheese



# Phonological Awareness

Phoneme Go Fish

PA. 029

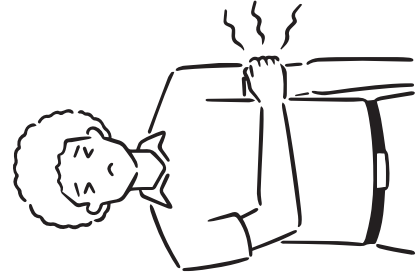
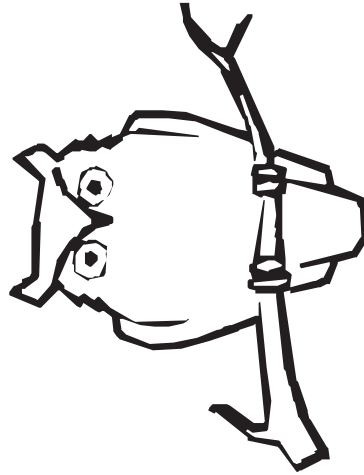
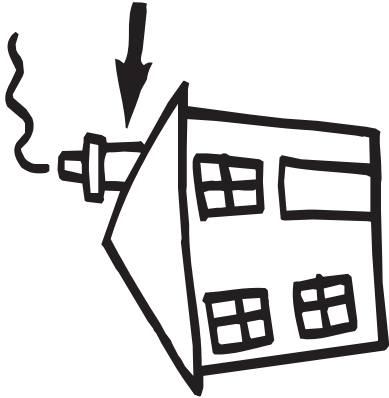

chimney, owl, ouch

